

Fittings for entrance doors

Round welded ht door pulls

- Aluminium
- Stainless steel
- Bronze

66 6522

66 6523



66 6522
Bracket centres (A) 1,000 mm to 2,600 mm
Tube Ø 35 × 2.5 mm

66 6523
Bracket centres (A) 2,100 mm to 2,800 mm
Tube Ø 40 × 4 mm

- Works-welded
- Made to order
- Desired **bracket combinations** (see below) are expressed by combining numbers, e.g. 66 6522 **5656**
- Bronze variant only available with bracket combinations 45 or 46/56
- The bracket spacing (A) is measured from the centre of the screw hole of one bracket to the centre of the screw hole of the other bracket; the tube length of the door pull is determined by adding or subtracting the differential dimensions provided on page 677 prior to welding the parts together at the plant.

Bracket combinations

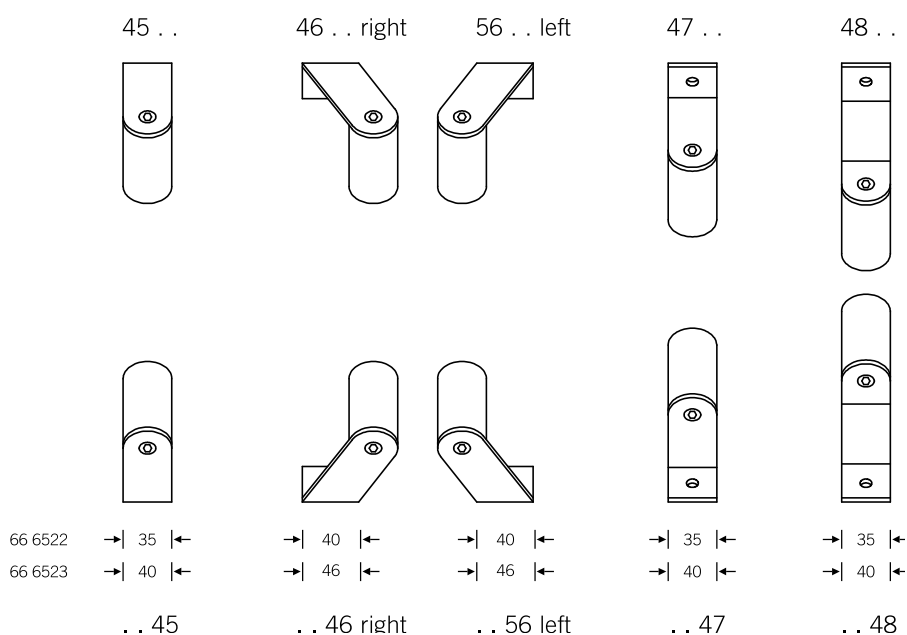

When using oval ht door pulls (for self-assembly or in the works-welded variant), structural requirements and conditions on site must be considered. These handles are no substitute for gymnastic bars and

must not be used as safety barriers at hazardous building openings. If in doubt please consult the architect or structural engineer in charge. Fixing system details can be found on page 691 ff.

Fittings for entrance doors

Door pull from the round ht kit

■ Aluminium
 ■ Stainless steel
 ■ Bronze



66 6801 ■

Tube $\varnothing 35 \times 1.5$ mm
 Lengths up to 1,500 mm

- High degree of flexibility, such as on the construction site
- Handle systems, handrails, safety rails, etc. can be cut to size on site, configured and installed from FSB tubes and brackets
- We recommend works-welded variant FSB 66 6522 when bracket centres (A) measure 1,500 mm or more; see previous page
- For bracket centres (A) measuring 2,100 mm upwards, welded variant FSB 66 6522 is available; see page 676

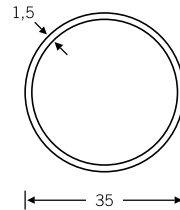

Cut-to-size dimensions and bracket combinations

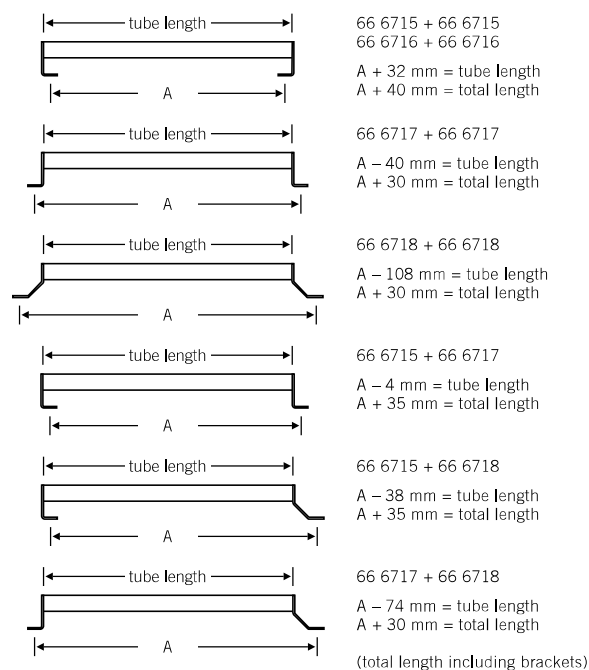

The tube length and bracket centres (A) have an important bearing on manufacturing, installation and ordering. The bracket spacing (A) is measured from the centre of the screw hole of one bracket to the centre of the screw hole of the other bracket. The tube length is calculated from the bracket centres (A) by adding or subtracting the differential dimensions provided here.

8a

When using oval ht door pulls (for self-assembly or in the works-welded variant), structural requirements and conditions on site must be considered. These handles are no substitute for gymnastic bars and

must not be used as safety barriers at hazardous building openings. If in doubt please consult the architect or structural engineer in charge. Fixing system details can be found on page 691 ff.

Fittings for entrance doors

Door-pull brackets from the round ht kit

- Aluminium
- Stainless steel
- Bronze

66 6715 ■

In-line bracket, joint angled 90° inwards, suitable for tube $\varnothing 35 \times 1.5$ mm

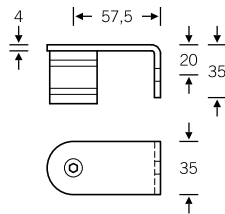

66 6716 ■

66 6716 014 (R) | 66 6716 015 (L)

Cranked 45° bracket, joint angled 90° inwards, suitable for tube $\varnothing 35 \times 1.5$ mm; pictured: right-hand model

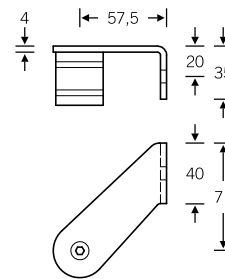

66 6717 ■

In-line bracket, joint angled 90° outwards, suitable for tube $\varnothing 35 \times 1.5$ mm

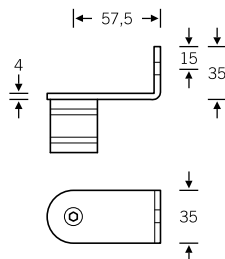

66 6718 ■

Bracket for swing doors, suitable for tube $\varnothing 35 \times 1.5$ mm

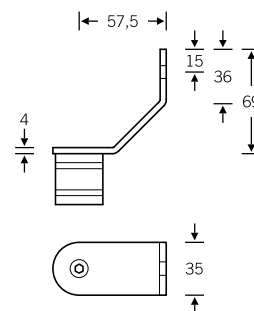

Screw hole $\varnothing 8.5$ mm
Safety clearance $S = 52$ mm
(see page 690)

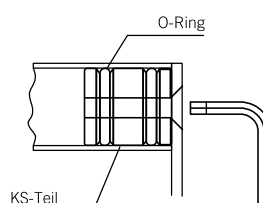

Once the tube has been cut to size (bracket centres A +/- differential dimension), the expansion plugs for the brackets selected are inserted into the two ends of the tube and activated by screwing them in at the top.

Fittings for entrance doors

Door-pull accessories from the round ht kit

In the case of door pulls from the round ht kit that are used on high-traffic doors or with bracket centres (A) measuring 1,500–2,100 mm, FSB recommends reinforcing them with the aid of the dedicated accessories presented here – or even better, opting for works-welded variants FSB 66 6522 or 66 6523 (see page 676).

Assembly instructions: cut the hollow steel bar to a length equal to that of the pull tube minus 100 mm. Slide spacer sleeves over the bar at intervals of 350 mm and secure. Insert the assembly into the pull tube and fit the hardware.

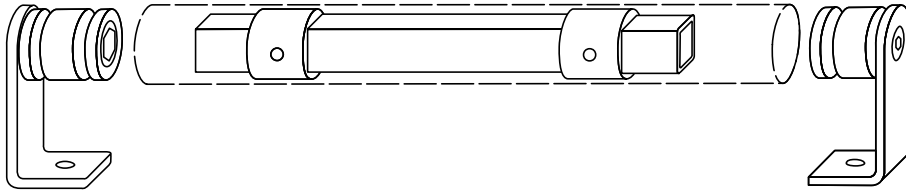

66 6801

Hot-dip galvanised hollow steel bar

66 6801 02020

20 × 20 × 2 mm
Stock length supplied 3,000 mm

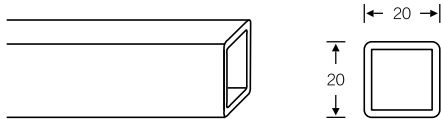

66 6719

Plastic

Spacer sleeve with securing screw

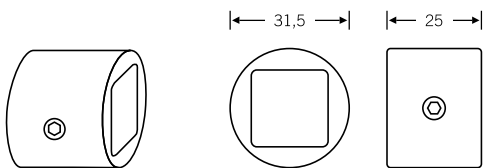

05 03..



05 0313 00880 (M8 × 80 mm)
Grub screw

05 0316 00840 (M8)
Headless wood screw

05 0320 00800 (M8)
Stainless steel domed nut